

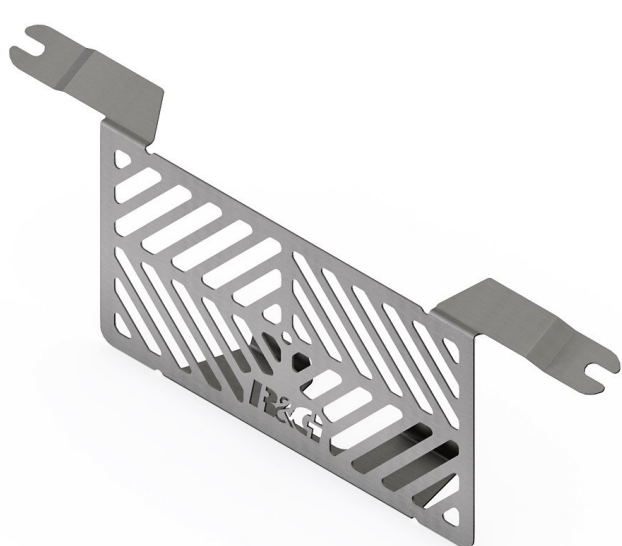

## FITTING INSTRUCTIONS FOR SCG0010 STAINLESS-STEEL OIL COOLER GUARD BMW S1000RR 2019



Picture A



Picture B

**THIS KIT CONTAINS THE ITEMS PICTURED AND LABELLED OVER PAGE.**

SOME PARTS MAY BE SHOWN FOR CLARITY OF INSTRUCTIONS ONLY.

DO NOT PROCEED UNTIL YOU ARE SURE ALL PARTS ARE PRESENT.

**PLEASE READ ALL INSTRUCTIONS BEFORE PROCEEDING.**

**IF IN ANY DOUBT WHEN FITTING OUR PRODUCTS, CONSULT ONE OF OUR DEALERS  
OR HAVE FITTED BY A QUALIFIED TECHNICIAN.**

PLEASE NOTE THAT THE WAY THE KIT IS PACKED DOES NOT NECESSARILY REPRESENT THE WAY OF  
MOUNTING TO THE BIKE.

IN THE EVENT OF RUBBER WASHERS BEING USED TO HOLD COMPONENTS ONTO BOLTS,  
THESE RUBBER WASHERS CAN BE THROWN AWAY.

**DIGITAL COPIES OF THESE INSTRUCTIONS ARE AVAILABLE FROM:**

[WWW.RG-RACING.COM](http://WWW.RG-RACING.COM)

R&G Racing

Unit 1, Shelley's Lane, East Worldham, Alton, Hampshire GU34 3AQ.

Tel: +44 (0)1420 89007 Fax +44 (0)1420 87301 [www.rg-racing.com](http://www.rg-racing.com) Email: [info@rg-racing.com](mailto:info@rg-racing.com)



<u>TOOLS REQUIRED</u>	<u>GENERAL TORQUE SETTINGS</u>
<ul style="list-style-type: none"> <li>T25 Torx Tool</li> </ul>	<p>M4 BOLT = 8Nm                      M5 BOLT = 12Nm                      M6 BOLT = 15Nm                      M8 BOLT = 20Nm                      M10 BOLT = 40Nm                      M12 BOLT = 40Nm</p>

**LEGEND**

ITEM No.	DESCRIPTION	QTY
ITEM 1	STAINLESS-STEEL OIL COOLER GUARD (SCG0010)	1
ITEM 2	SELF-ADHESIVE FOAM (100mm LENGTH)	6



Picture 1



Picture 2



Picture 3



Picture 4



Picture 5



Picture 6

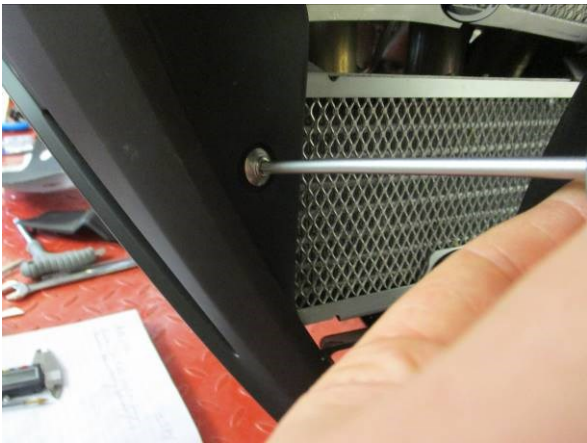

Picture 7



Picture 8

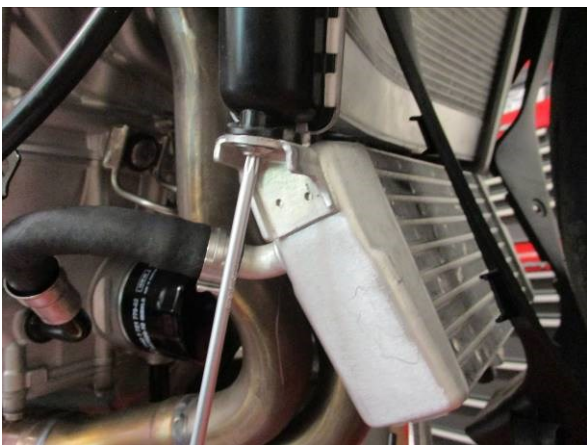

Picture 9

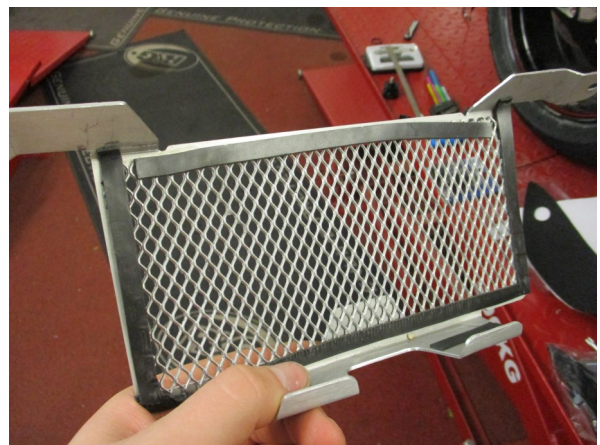

Picture 10

R&G Racing

Unit 1, Shelley's Lane, East Worldham, Alton, Hampshire GU34 3AQ.

Tel: +44 (0)1420 89007 Fax +44 (0)1420 87301 [www.rg-racing.com](http://www.rg-racing.com) Email: [info@rg-racing.com](mailto:info@rg-racing.com)



Picture 11



Picture 12

### **FITTING INSTRUCTIONS**

- Starting on the right-hand side of the bike, remove the 5x fairing bolts shown in pictures 1-5 using a T25 Torx key/socket.
- Using the same tool for all remaining steps, remove the bolt securing the two sides of the fairing together, as shown in picture 6.
- Remove the 4x lower inner fairing bolts as shown in picture 7, then the 4x upper inner fairing bolts as shown in picture 8.
- Gently remove the RHS fairing, then repeat previous steps for the LHS fairing.
- Remove the 2x bolts joining the radiator guard to the oil cooler, as shown in picture 9.
- Arrange and fix the strips of protective foam (item 2) to the inner frame and lower hook contact surface of the oil cooler guard (item 1), as shown in picture 10.
- Slide the lower hooks over the underside of the oil cooler, as shown in picture 11.
- Position the oil cooler guard tabs between the radiator and oil cooler joining points as shown in picture 12, then secure with the original bolts.
- Refit all panels.

ISSUE 1 - 16/08/2019 (FB)

R&G Racing

Unit 1, Shelley's Lane, East Worldham, Alton, Hampshire GU34 3AQ.

Tel: +44 (0)1420 89007 Fax +44 (0)1420 87301 [www.rg-racing.com](http://www.rg-racing.com) Email: [info@rg-racing.com](mailto:info@rg-racing.com)



#### CONSUMER NOTICE

The catalogue description and any exhibition of samples are only broad indications of the Products and R&G may make design changes which do not diminish their performance or visual appeal and supplying them in such state shall conform to the order. The Buyer acknowledges no representation or warranty (other than as to title) has been given or will apply to the Products other than those in R&G's order or confirmation and the Buyer confirms it has chosen the Products as being of merchantable quality and suitable for its particular purposes. Where R&G fits the Products or undertakes other services it shall exercise reasonable skill and care and rectify any fault free of charge unless the workmanship has been disturbed. The Buyer is responsible for ensuring that the warranty on the motorcycle is not affected by the fitting of the Products. On return of any defective Products R&G shall at its option either supply a replacement or refund the purchase money but shall not be liable if the Products have been modified or used or maintained otherwise than in accordance with R&G's or manufacturer's instructions and good engineering practice or if the defect arises from accident or neglect. Other than identified above and subject to R&G not limiting its liability for causing death and personal injury, it shall not be liable for indirect or consequential loss and otherwise its liability shall be limited to the amounts paid by the Buyer for the Products or the fitting or service concerned. These terms do not affect the Buyer's statutory rights.

#### R&G RETURNS POLICY (NON-FAULTY GOODS)

Returns must be pre-authorized (if not pre-authorized the return will be rejected). Goods may only be returned direct to us if they were purchased direct from us (customer must prove if necessary). Otherwise to be returned to original vendor. Goods must be in re-sellable condition, in the opinion of R&G. All returns are subject to a 25% restocking and handling fee (25% of the gross value exc. P&P – at the prevailing price at time of purchase). The customer must pay any and all carriage charges. No returns of discontinued products, unless within 14 days of purchase. This policy does not affect your statutory rights and does not refer to faulty goods.

R&G Racing

Unit 1, Shelley's Lane, East Worldham, Alton, Hampshire GU34 3AQ.

Tel: +44 (0)1420 89007 Fax +44 (0)1420 87301 [www.rg-racing.com](http://www.rg-racing.com) Email: [info@rg-racing.com](mailto:info@rg-racing.com)



**NOTICE DE MONTAGE POUR SCG0010  
PROTECTION DE REFROIDISSEUR D'HUILE  
BMW S1000RR 2019**

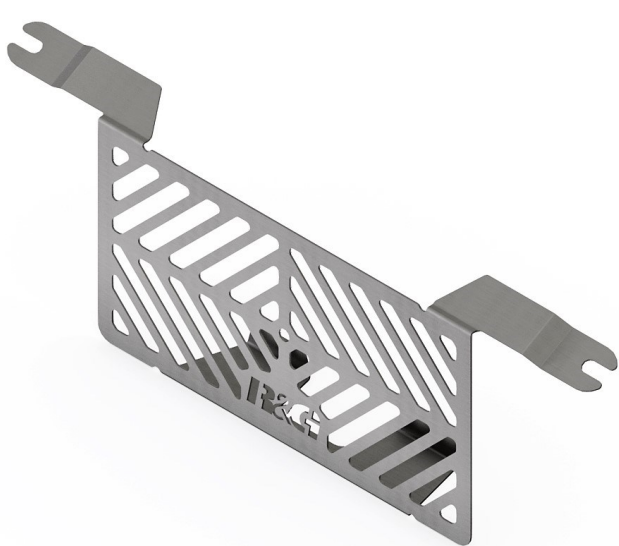

Photo A



Photo B

**LE KIT CONTIENT LES ARTICLES EN PHOTO ET ETIQUETTES SUR LA PAGE**

LES PARTIES PRÉSENTÉES PEUVENT ÊTRE UNIQUEMENT REPRESENTATIVES POUR LA CLARTE DES INSTRUCTIONS

NE PAS PROCÉDER AU MONTAGE AVANT DE VOUS ÊTRE ASSURÉ QUE TOUTES LES PIÈCES SOIENT PRÉSENTES.

**SVP, LIRE L'ENSEMBLE DE LA NOTICE AVANT DE PROCÉDER AU MONTAGE.**

La façon dont le kit est emballé ne correspond pas forcément à la façon de monter les pièces sur la moto .

NOTEZ QUE SI LES KITS SONT EMBALLÉS AVEC DES RONDELLES EN CAOUTCHOUC SERVANT À TENIR LES COMPOSANTS, CES RONDELLES DOIVENT ÊTRE JETÉES.

**NOTICE DISPONIBLE AU TÉLÉCHARGEMENT SUR : [WWW.RG-RACING.COM](http://WWW.RG-RACING.COM)**

R&G Racing

Unit 1, Shelley's Lane, East Worldham, Alton, Hampshire GU34 3AQ.

Tel: +44 (0)1420 89007 Fax +44 (0)1420 87301 [www.rg-racing.com](http://www.rg-racing.com) Email: [info@rg-racing.com](mailto:info@rg-racing.com)



<b><u>OUTILS REQUIS</u></b>	<b><u>VALEURS DE SERRAGE</u></b>
<ul style="list-style-type: none"> <li>Clé Torx T25</li> </ul>	M4 BOULON = 8Nm M5 BOULON = 12Nm M6 BOULON = 15Nm M8 BOULON = 20Nm M10 BOULON = 40Nm M12 BOULON = 40Nm

### **LEGENDE**

<b>ARTICLE No.</b>	<b>DESCRIPTION</b>	<b>QTY</b>
ARTICLE 1	PROTECTION REFROIDISSEUR D'HUILE (SCG0010)	1
ARTICLE 2	MOUSSE AUTOCOLLANTE (100mm DE LONG)	6

### **NOTICE DE MONTAGE**

- En commençant du côté droit de la moto, retirez les 5 boulons de carénage représentés sur les photos 1 à 5 à l'aide d'une clé / douille T25 Torx.
- En utilisant le même outil pour toutes les étapes restantes, retirez le boulon fixant les deux côtés du carénage ensemble, comme indiqué sur la photo 6.
- Retirez les 4 boulons inférieurs du carénage intérieur comme indiqué sur la photo 7, puis les 4 boulons supérieurs du carénage comme indiqué sur la photo 8.
- Retirez délicatement le carénage du côté droit puis répétez les étapes précédentes pour le carénage gauche.
- Retirez les 2 boulons reliant la protection du radiateur au refroidisseur d'huile, comme indiqué sur la photo 9.
- Disposez et fixez les bandes de mousse de protection (article 2) sur le cadre intérieur et sur la surface de contact avec le crochet inférieur de la protection du refroidisseur d'huile (article 1), comme indiqué sur la photo 10.
- Faites glisser les crochets inférieurs au dessous du refroidisseur d'huile, comme indiqué sur la photo 11.
- Placez les languettes de protection du refroidisseur d'huile entre les points de jonction du radiateur et du refroidisseur d'huile, comme indiqué sur la photo 12, puis fixez-les avec les boulons d'origine.
- Remonter l'ensemble des carénages.

ISSUE 1 - 16/08/2019 (FB)

R&G Racing

Unit 1, Shelley's Lane, East Worldham, Alton, Hampshire GU34 3AQ.

Tel: +44 (0)1420 89007 Fax +44 (0)1420 87301 [www.rg-racing.com](http://www.rg-racing.com) Email: [info@rg-racing.com](mailto:info@rg-racing.com)



## MONTAGEANLEITUNG FÜR SCG0010 EDELSTAHL ÖLKÜHLERSCHUTZ BMW S1000RR 2019



Abbildung A



Abbildung B

### **ALLE KIT-TEILE SIND UNTEN ABGEBILDET UND GEKENNZEICHNET.**

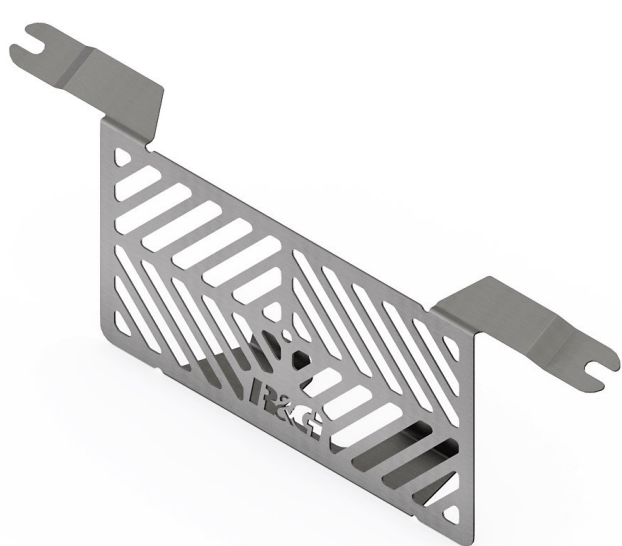
DIE ABGEBILDETEN TEILE DIENEN LEDIGLICH ZUR ERKLÄRUNG.

ÜBERPRÜFEN SIE ZUERST, DASS ALLE TEILE VORHANDEN SIND.

LESEN SIE DIE MONTAGEANLEITUNG KOMPLETT DURCH, BEVOR SIE ANFANGEN.

**WENN SIE BEI DER MONTAGE DIESER PRODUKTES UNSICHER SIND , BITTE EINEN UNSERER HÄNDLER KONTAKTIEREN ODER DAS KIT VON EINEM QUALIFIZIERTEN ZWEIRAD-MECHANIKER MONTIEREN LASSEN.**

DIE VERPACKUNG DER TEILE STELLT NICHT DIE REIHENFOLGE DER MONTAGE DAR.

HINWEIS FÜR KITS MIT PLASTIKUNTERLEGSCHLEIBEN AN DEN SCHRAUBEN –  
DIESE PLASTIK-UNTERLEGSCHLEIBEN WERDEN NICHT FÜR DEN EINBAU BENÖTIGT!

**EINE DIGITALE VERSION DIESER MONTAGEANLEITUNG KANN AUF  
FOLGENDER SEITE HERUNTERGELADEN WERDEN:**

[WWW.RG-RACING.COM](http://WWW.RG-RACING.COM)

R&G Racing

Unit 1, Shelley's Lane, East Worldham, Alton, Hampshire GU34 3AQ.

Tel: +44 (0)1420 89007 Fax +44 (0)1420 87301 [www.rg-racing.com](http://www.rg-racing.com) Email: [info@rg-racing.com](mailto:info@rg-racing.com)





<b><u>SIE BENÖTIGEN FOLGENDES WERKZEUG</u></b>	<b><u>ALLGEM. ANZUGSDREHMOMENT</u></b>
<ul style="list-style-type: none"> <li>T25 Torx-Schlüssel</li> </ul>	M4 SCHRAUBE = 8Nm M5 SCHRAUBE = 12Nm M6 SCHRAUBE = 15Nm M8 SCHRAUBE = 20Nm M10 SCHRAUBE = 40Nm M12 SCHRAUBE = 40Nm

### **LIEFERUMFANG**

<b>ARTIKELN R.</b>	<b>BESCHREIBUNG</b>	<b>MENGE</b>
ARTIKEL 1	EDELSTAHL ÖLKÜHLERSCHUTZ (SCG0010)	1
ARTIKEL 2	SELBSTKLEBENDER SCHAUMSTOFF (100mm LÄNGE)	6

### **MONTAGEANLEITUNG**

- Fangen Sie an der rechten Seite des Motorrades an und entfernen Sie die 5x Verkleidungsschrauben, die in den Abbildungen 1-5 abgebildet sind mit einem T25 Torx-Schlüssel.
- Mit dem gleichen Werkzeug entfernen Sie die Schraube, die die zwei Seiten der Verkleidung zusammenhält—siehe Abbildung 6.
- Entfernen Sie die 4x inneren Verkleidungsschrauben unten wie in Abbildung 7 abgebildet, danach die 4 x inneren Verkleidungsschrauben oben entfernen wie in Abbildung 8 abgebildet.
- Vorsichtig die Seitenverkleidung an der rechten Seite entfernen und danach die zuvor beschriebenen Schritte wiederholen, um die Seitenverkleidung an der linken Seite zu entfernen.
- Entfernen Sie die 2x Schrauben, die den Kühlerschutz am Ölkühler befestigen wie in Abbildung 9 abgebildet.
- Die Schaumstoffstreifen (Artikel 2) an der Innenseite des Rahmens sowie an der Auflagefläche der unteren Haken am Ölkühlerschutz (Artikel 1) anbringen wie in Abbildung 10 abgebildet.
- Schieben Sie die unteren Haken über die Unterseite des Ölkühlers wie in Abbildung 11 abgebildet.
- Positionieren Sie die Laschen für die Ölkühlerschutz zwischen dem Kühler und den Verbindungspunkten des Ölkühlers wie in Abbildung 12 abgebildet und danach mit den Originalschrauben befestigen.
- Refit all panels.

ISSUE 1 - 16/08/2019 (FB)

R&G Racing

Unit 1, Shelley's Lane, East Worldham, Alton, Hampshire GU34 3AQ.

Tel: +44 (0)1420 89007 Fax +44 (0)1420 87301 [www.rg-racing.com](http://www.rg-racing.com) Email: [info@rg-racing.com](mailto:info@rg-racing.com)